

Device part number

MIN-101C

Device name

MinION Mk1C

Short description

The Oxford Nanopore Technologies® MinION™ Mk1C is a compact, portable device, combining the hardware for running nanopore sequencing experiments with fully integrated compute used for basecalling and onward analysis. The device is entirely self-contained and requires no other computing resource.

Product overview

The MinION Mk1C can be used with MinION flow cells and the Flongle adapter and flow cells. Users can operate the system in an offline or online mode, enabling full sequencing and analysis to be performed in the lab and field. A high-definition touch screen means users receive constant feedback regarding experiment progression and can easily interact with the device, without additional hardware.

Technical specifications

Component	Specification
Size and weight	H 32 mm x L 142 mm x W 118 mm; 440 g
Power	<ul style="list-style-type: none">• Supplied with a 6.3-19.6 VDC power supply• Max rated current 10 A• Max rated power 60 W
Compute spec	1 TB SSD Storage, 8 GB RAM, GPU embedded analysis accelerator (ARM processor 6 cores, 256 core GPU)
Connectivity	<ul style="list-style-type: none">• 1x USB 2.0• 1x eSATA (currently non-functional)• 1x microSD card• 1x 1 GB Ethernet• Wi-Fi connectivity
Pre-loaded software	Linux OS, MinKNOW and Guppy
Security	Kensington Nano Security Slot
Environmental conditions	<ul style="list-style-type: none">• Designed to sequence at +10°C to +30°C*• Do not cover vents on the top or sides of the device• Indoor use• Altitude up to 2,000 metres• Maximum relative humidity 80% for temperatures up to 31°C, decreasing linearly to 50% relative humidity at 40°C• Applicable pollution degree 2 in the intended environment

* Functional range of electronics +5°C to +40°C

Shipping and logistics

The Oxford Nanopore Technologies MinION Mk1C device is stored and shipped at ambient temperature (15–25°C).

The delivery charges are calculated when a quote is raised or during checkout. Once an order is made, the delivery ID and delivery information can be tracked in the Store.

IT requirements

The MinION Mk1C comes pre-configured with MinKNOW and with optimised capacity to run the range of MinION experiments. The on-board GPU operates as a basecalling accelerator to drive through the experimental data at an optimal rate.

In addition, the 1 TB SSD storage provides an average capacity of roughly 50 Gbases, stored in .fast5 and/or FASTQ format.

Device connectivity is provided through a number of options: WiFi, Ethernet and USB 2.0. Users can choose the option most suitable to their environment.

The MinION Mk1C is installed with a Linux OS, and the integral software. MinKNOW Core operates the sequencing experiments on the MinION. It performs data acquisition, real-time analysis and feedback, basecalling, data streaming, providing device control, and ensuring that the platform chemistry is performing correctly to run the samples.

The MinKNOW Graphical User Interface (GUI) can control and configure the MinION to coordinate a sequencing experiment, and is accessed directly via the integrated high-definition touchscreen. The GUI has internal features that allow the user to monitor and define parameters in a sequencing experiment.

Safety and legal information

Intended use of the MinION Mk1C device:

The Oxford Nanopore Technologies MinION Mk1C device is an electronic analysis system for use in scientific research. The core technology is built around a nanopore that is able to detect single molecule events including nucleic acids (DNA/RNA), proteins and small molecules.

This product is for research use only.

Special considerations for MinION Mk1C power supply units

Customers are advised to use the supplied 6.3-19.6 VDC power supply.

If a different power source is used, it must be safety isolated with a fuse or circuit breaker. This must be in line with the rated values for MinION Mk1C and be previously approved according to national standards and regulations.

Special considerations for MinION Mk1C radio features

FCC ID for MIN-101C: 2ARGS-*****

This product contains FCC ID: VOB-P3310

Warning statement for modifications

WARNING: The FCC requires that you be notified that any changes or modifications to this device not expressly approved by Oxford Nanopore Technologies could void the user's authority to operate the equipment.

FCC Part 15 Statement - unintentional transmitters

Note: This equipment has been tested and found to comply with the limits for a Class B digital device, pursuant to Part 15 of the FCC rules. This device complies with Part 15 of the FCC Rules. Operation is subject to the following two conditions: (1) this device may not cause harmful interference, and (2) this device must accept any interference received, including interference that may cause undesired operation. Changes or modifications not expressly approved by the party responsible for compliance could void the user's

authority to operate the equipment. This equipment has been tested and found to comply with the limits for a Class B digital device, pursuant to Part 15 of the FCC Rules. These limits are designed to provide reasonable protection against harmful interference in a residential installation. This equipment generates, uses and can radiate radio frequency energy and, if not installed and used in accordance with the instructions may cause harmful interference to radio communications. However, there is no guarantee that interference will not occur in a particular installation.

If this equipment does cause harmful interference to radio or television reception, which can be determined by turning the equipment off and on, the user is encouraged to try to correct the interference by one or more of the following measures:

- Reorient or relocate the receiving antenna.
- Increase the separation between the equipment and receiver.
- Connect the equipment into an outlet on a circuit different from that to which the receiver is connected.
- Consult the dealer or an experienced radio/TV technician for help.

FCC Part 15 Statement - intentional transmitters

This equipment complies with FCC radiation exposure limits set forth for an uncontrolled EM environment. This equipment should be installed and operated with minimum distance 20 cm between the radiator and your body. This transmitter must not be co-located or operating in conjunction with any other antenna or transmitter.

Declaration of conformity

The MinION Mk1C conforms to the EMC and Electrical Safety directives as outlined in the EC Declaration of Conformity.

EC DECLARATION OF CONFORMITY

Manufacturers Name: Oxford Nanopore Technologies plc

Manufacturers Address: Gosling Building
Edmund Halley Road
Oxford Science Park
Oxford,
OX4 4DQ,
United Kingdom

Declares that the product: Model name: MinION MK1C
Model part No. MIN-101C / ONT-00-00091-00
Equipment Type: Laboratory Equipment

Conforms to the following Directives:
Radio Equipment Directive (RED): 2014/53/EU
Restriction of the use of certain hazardous substances in
electrical and electronic equipment (RoHS): 2011/65/EU
Waste electrical and electronic equipment (WEEE): 012/19/EU

Verified to the following standards:

EMC	EN 61326-2-1:2013, referencing EN 61326-1 and ETSI EN 301 489-17 V3.1.1 referencing ETSI EN 301 489-1 V2.1.1. Emissions class B.
Electrical Safety	IEC 61010-1:2010, IEC 61010-2-010:2014, IEC 61010-2-081:2015
Radio and RF Exposure	EN 300 328 V2.1.1 EN 301 893 V2.1.1 EN 300 440 V2.1.1 RF Exposure: EN 62311:2008

We, hereby declare that the equipment specified above conforms to the above directives and standards specified.

Signature: _____ Date: _____

Full Name: Alison Forrow
Position: Head of Quality Assurance

Document: D-0542
Revision: 2

License and Warranty

The license and warranty contract ensures your instrument is performing optimally by providing the latest up-to-date hardware and software. The contract guarantees that Oxford Nanopore Technologies support obligations are delivered during the contract period as laid out in sections 4 and 7 of the [Nanopore Product Terms and Conditions](#).

For more information, see the [Device Warranty](#) page on the Oxford Nanopore Store.

What's in the box

The MinION Mk1C is shipped together with an AC/DC adapter, pin-plugs for all regions, a USB cable and a Configuration Test Cell (CTC).

Configuration is the process of testing that communication between the MinION device and the control software on the host computer is operational prior to experimental work being performed. This is carried out in the absence of any chemistry and uses a specific flow cell known as the Configuration Test Cell (CTC).

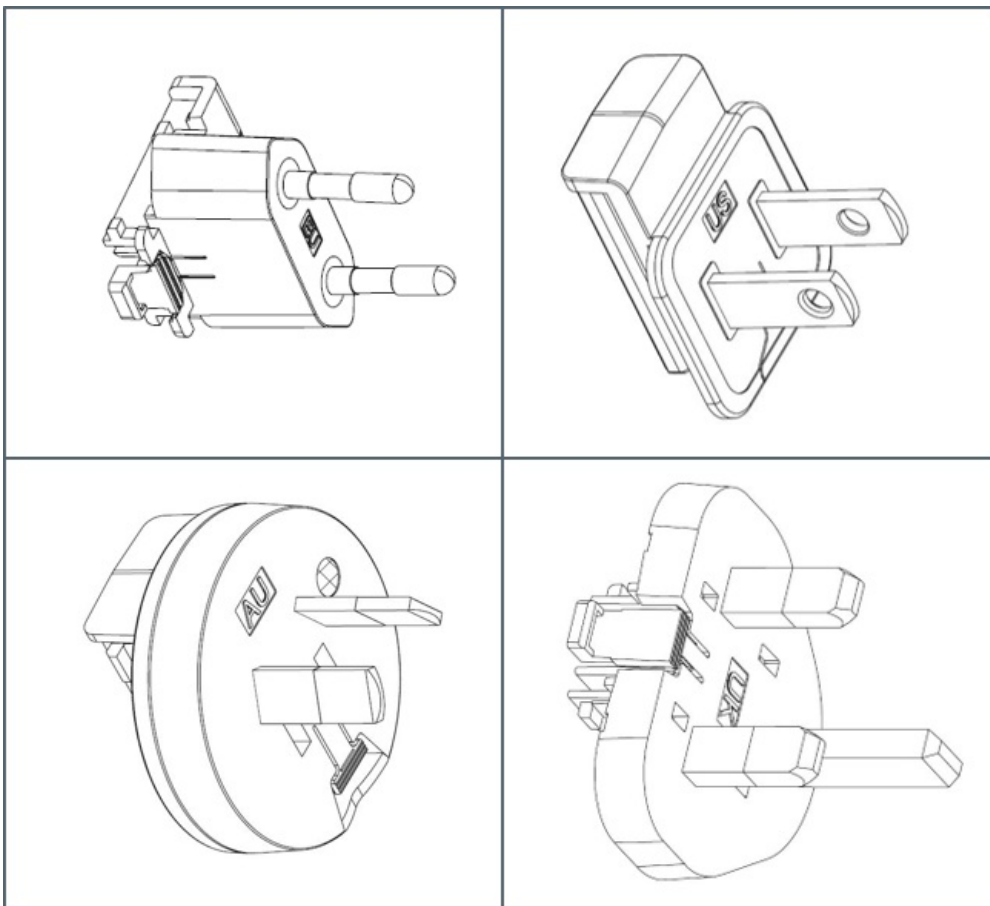

Product cross-compatibility

The MinION Mk1C can be used together with:

Flow cells

- MinION/GridION Flow Cell (FLO-MIN114)
- MinION/GridION Flow Cell – RNA (FLO-MIN004RA)
- Flongle Flow Cell (FLO-FLG114)

Kits

- Ligation Sequencing Kit V14 (SQK-LSK114)
- Ligation Sequencing Kit XL V14 (SQK-LSK114-XL)
- Ultra-Long DNA Sequencing Kit V14 (SQK-ULK114)
- Multiplex Ligation Sequencing Kit XL V14 (SQK-MLK114.96-XL)
- Rapid Sequencing Kit V14 (SQK-RAD114)
- Rapid Barcoding Kit 24 V14 (SQK-RBK114.24)
- Rapid Barcoding Kit 96 V14 (SQK-RBK114.96)
- Rapid PCR Barcoding Kit 24 V14 (SQK-RPB114.24)
- Native Barcoding Kit 24 V14 (SQK-NBD114.24)
- Native Barcoding Kit 96 V14 (SQK-NBD114.96)
- 16S Barcoding Kit 24 V14 (SQK-16S114.24)
- cDNA-PCR Sequencing Kit V14 (SQK-PCS114)
- cDNA-PCR Barcoding Kit V14 (SQK-PCB114.24)
- Direct RNA Sequencing Kit (SQK-RNA004)

Software

Basecalling:

- MinKNOW
- Dorado

Basecalled reads are available as POD5 and FASTQ files.

Downstream analysis:

- EPI2ME
- Oxford Nanopore-developed tools and pipelines
- Customer-developed tools and pipelines

Change log

Date	Version	Changes made
24th April 2024	V8	<ul style="list-style-type: none"> - Corrections made in "Technical specifications" - Updated the Declaration of Conformity - Updated the License and Warranty information - Updated the product cross-compatibility
11th August 2022	V7	<ul style="list-style-type: none"> - The Technical Specifications table has been updated to say "Designed to sequence at +10°C to +30°C / Functional range of electronics +5°C to +40°C" - Cross-compatibilities have been updated to include the Ligation Sequencing Kit V14 (SQK-LSK114) and the R10.4.1 flow cells (FLO-MIN114)
22nd February 2022	V6	Updates to kit compatibilities

Date	Version	Changes made
3rd February 2022	V5	Declaration of Conformity added
10th August 2021	V4	Updated "Environmental conditions" in "Technical specifications"
28th April 2021	V3	<ul style="list-style-type: none">- Added microSD under Connectivity and Kensington Nano Security slot under Security in "Technical specifications"- Updated product cross-compatibilities to remove references to FLO-MIN107 and FLO-MIN110 as well as a full list of FLO-MIN106-compatible kits
Nov 2020	V2	Updates to kit compatibilities